

Technical Specification Document

Harvest Radiant

Technical Specifications

1.	System Overview	3
2.	Design and Sizing	4
	2.1 Floor Design	4
	2.2 System Sizing	5
3.	Operation & Performance	6
	3.1 Operation	6
	3.2 Domestic Hot Water Performance	6
	3.3 Thermal Battery Dispatchable Energy	7
4.	Plumbing	11
	4.1 Field Supplied Plumbing Schedule - Potable	12
	4.2 Field Supplied Plumbing Schedule - Radiant	13
5.	Low Voltage Wiring	14
6.	Commissioning	15
7.	Support	15
8.	Service	15

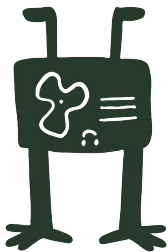

Harvest Radiant integrates a Harvest Pod, the SANCO2 heat pump water heater, and a radiant floor into a smart thermal battery system for heating and DHW applications up to 30 kBtu/hr. Harvest Radiant offers modulated heat delivery for premium comfort and efficiency.

As a smart thermal battery, Harvest Radiant will shift heat pump operation from times of high costs and emissions to times of low costs and emissions, while always delivering heating and hot water when it is needed. Harvest offers up to 30% reductions in heating and hot water energy costs and 90% in CO2 emissions compared to gas. It protects your home from rising electrical rates and provides resilient dispatchable heating energy whenever you need it.

Harvest Radiant works well with radiant flooring that has a high radiative transfer capacity, such as concrete or engineered radiant transfer materials. In addition, Harvest Radiant works well alongside solar photovoltaic and electrochemical battery systems (not required).

1. System Overview

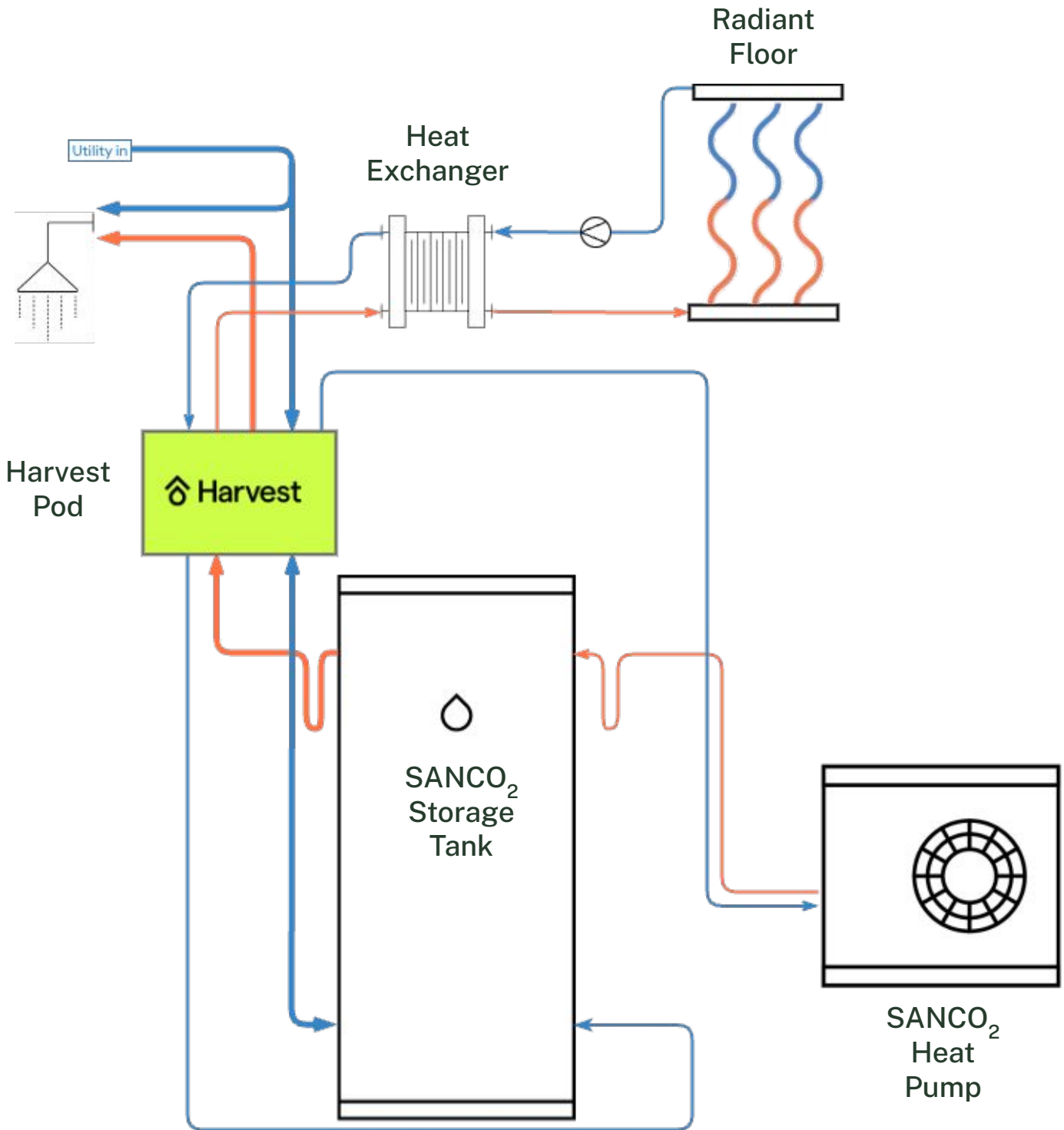

2. Design & Sizing

2.1 Floor Design

The Harvest Radiant system is considered a low temperature radiant system. As such, there are a few practices that can help get the best performance out of a lower temperature radiant floor:

- Use longer loop length than typical, to help achieve a low return temperature, e.g, 250-500 ft length.
- Use a “double back” layout, i.e. the warm supply pipe is always next to the cooler return pipe, to achieve a uniform temperature across the floor

Optimal piping layout



2.2 Floor Heating Capacity

The higher the radiative transfer capacity of the floor, the better system performance and efficiency will be. In addition, the calculated heating capacity of the floor should always exceed the design load of the building.

Calculate the heating capacity of the floor:

$$\text{Floor capacity} = \text{heat flux (BTU/sqft/hr)} * \text{heated floor area (sqft)}$$

Heat Flux (BTU/sqft/hr)		Flooring		
		Polished concrete or tile	Wood	Carpet or area rug
Radiant transfer material	Concrete	30	15	5
	Engineered radiant	20-30	10-15	3-5
	Staple-up	10	5	2

2.3 System Sizing

If the design load is less than the floor heating capacity (see Section 2.2), this chart can be used to determine the configuration of the Harvest Radiant system – the number of SanCO₂ heat pumps and tank size.

Sizing							
CA Climate Zone	Design Temp. (F)	SanCO2 HPHW		1	1	1	2
		Storage Volume (gal)		83	119	166	119
CZ2 (Santa Rosa)	32	Variable Heating Capacity	Peak* (kBtu/hr)	16.2	24.8	31.2	32.0
			Constant (kBtu/hr)	12.2	12.2	12.2	25.5
		Daily Heating Capacity (kBtu/day)		293	293	293	613
CZ3 (Oakland)	40	Variable Heating Capacity	Peak* (kBtu/hr)	14.8	23.4	29.9	30.7
			Constant (kBtu/hr)	10.9	10.9	10.9	22.9
		Daily Heating Capacity (kBtu/day)		262	262	262	550
CZ4 (San Jose)	38	Variable Heating Capacity	Peak* (kBtu/hr)	14.8	23.4	29.8	30.6
			Constant (kBtu/hr)	10.8	10.8	10.8	22.8
		Daily Heating Capacity (kBtu/day)		260	260	260	547
CZ12 (Sacramento)	37	Variable Heating Capacity	Peak* (kBtu/hr)	14.8	23.4	29.8	30.6
			Constant (kBtu/hr)	10.8	10.8	10.8	22.8
		Daily Heating Capacity (kBtu/day)		260	260	260	547

* Maximum heating capacity sustainable for 4 hrs

** The addition of the resistive Tank Booster can increase Daily Heating Capacity, and Constant Heating Capacity for sites on the margin.

3. Operation & Performance

3.1 Operation

The Harvest Pod serves four primary purposes:

- manage the thermal battery system’s state of charge,
- monitor and predict heating and hot water demand based on the weather forecast and occupant usage patterns,
- optimize the heat pump operating schedule to shift electricity usage from time of high price and emissions to times of low price and emissions, while always delivering heating and hot water whenever needed, and
- modulates heating delivery for control of the water return temperature which optimizes heat pump capacity and efficiency.

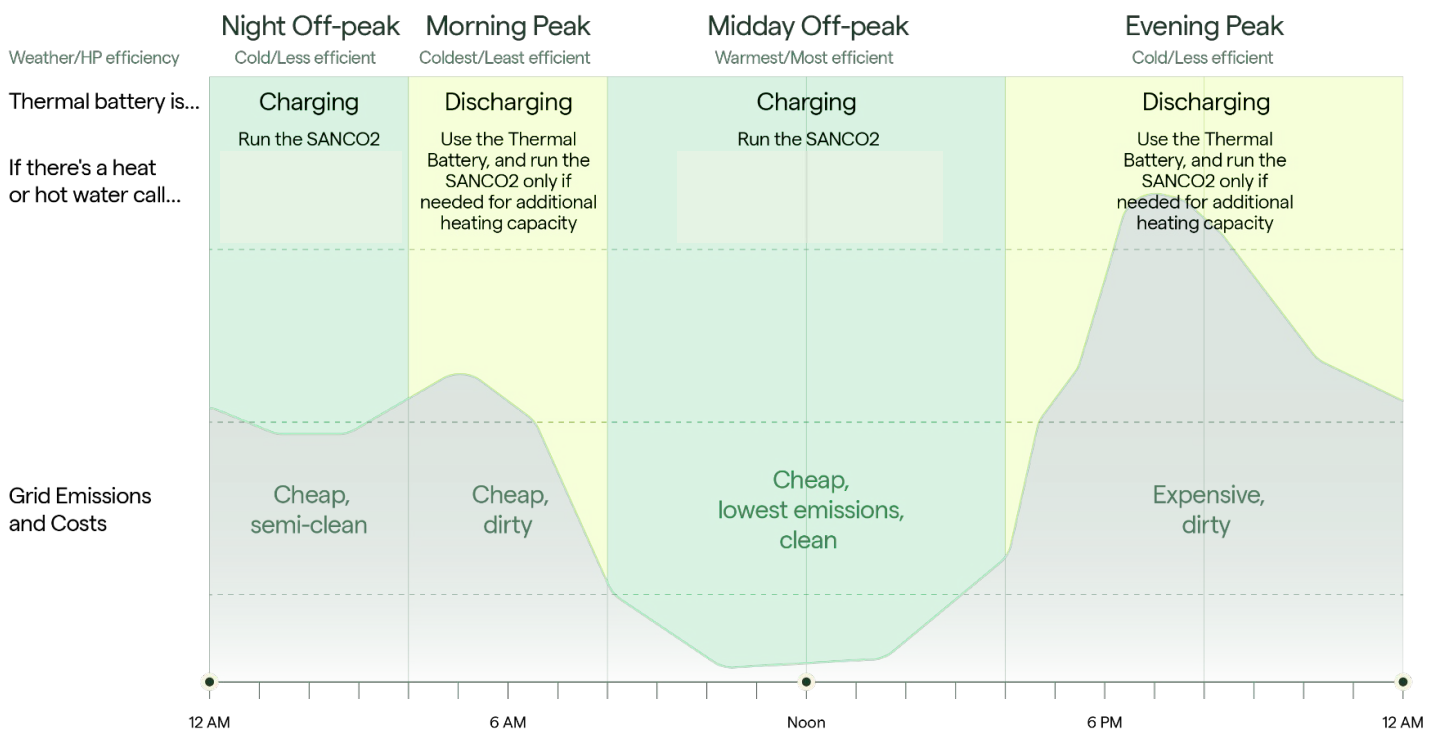

3.2 Domestic Hot Water Performance

The SANCO₂ HP, controlled to run at the cheapest and cleanest times of day by the Harvest Pod, provides remarkable domestic hot water performance, capacity, and recovery as part of the Harvest Open application.

Domestic Hot Water Performance*			
Tank Capacity	83 G	119 G	166 G
Coefficient of Performance	up to 5.5	up to 5.5	up to 5.5
Nominal Heating Capacity	15.4 kBtu/hr	15.4 kBtu/hr	15.4 kBtu/hr

* SANCO₂ performance data

3.3 Thermal Battery System Dispatchable Energy

Dispatchable energy is the quantity of energy from the thermal battery system that is used for heating and hot water during each discharge cycle. It represents how much energy can be shifted from peak times to off-peak times.

- In winter, the thermal battery system is typically cycled twice per day: once in the morning to serve heating and DHW needs, and once in the evening for heating and DHW needs. Dispatched energy is typically limited by thermal battery system capacity depending on the home energy needs.
- In summer, the thermal battery system is typically only charged once per day and only as much as needed to serve occupant needs until the next day. This may only be a third, or less, of the thermal battery system capacity depending on occupants' DHW needs, so dispatchable energy in summer is limited by energy demand rather than by thermal battery capacity.

Thermal Battery Dispatchable Energy Per Cycle			
	Storage Capacity		
	83 G	119 G	166 G
Heating Thermal Energy* (kBtu)	19	46	71
DHW Thermal Energy* ** (kBtu)	15	15	15
Combined DHW+Heating Thermal Energy* (kBtu)	34	61	86
Combined DHW+Heating Equivalent Electrical Load ***(kWh)	3.5	6.4	9.1

* available for both a morning and an evening peak period

** 30 gal of peak-coincident DHW usage

***Assuming an average COP of 2.8

4. System Components

4.1 Harvest Pod

The Harvest Pod controls the state of charge of the thermal energy storage, predicts heating and hot water needs based on occupants usage patterns and weather forecast, optimizes when the heat pumps operate so they are most efficient and cost effective, and prioritizes DHW over home heating as needed. It also enables remote monitoring to identify issues such as DHW leaks, HPWH failure to start, and circulator failure.

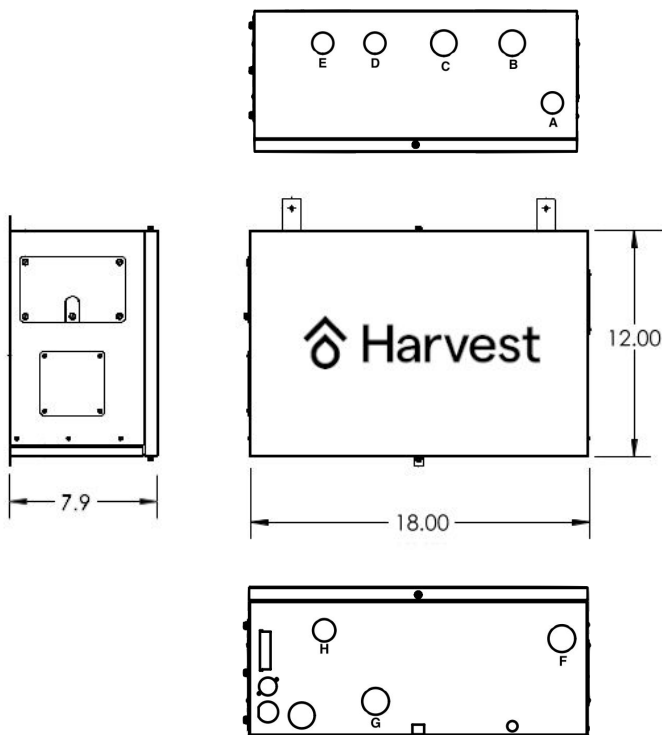

Configuration	Open
Specifications	
Operating Temperature	32°F to 122°F
Operating Humidity	5% to 95% rh
Max Hydronic Flow	1.6 gal/min
Power Supplies	24 VDC, 90W*; 24VAC**
Average Power Consumption	10 W
Wiring Connections	Screwless push-in terminal blocks & RJ45
Wiring	18 awg solid core & cat-5***
Networking	LAN/cat-5 (preferred) or wifi
Plumbing Connections	
Cold Water - Heat Pump (A)	1/2" NPT Male
Cold Water - Tank (F)	1/2" NPT Male
Hot Water - Tank (G)	3/4" NPT Male
DHW Hot (C)	3/4" NPT Male
Utility In (B)	3/4" NTP Male
Supply - To Coil / Heat Exchanger (D)	1/2" NPT Male
Return - To Coil / Heat Exchanger (E)	1/2" NPT Male
Return - Tank (H)	1/2" NPT Male
Dimensions	
Weight	33 lbs
Max Pipe Length to Coil	65 ft
Max Lift to Coil	35 ft
Max Incoming Water Pressure	75 psig
* Appropriate 24VDC Power Supply Included ** 24VAC Typically Supplied by R/C Connections on Air Handler *** Cat-5 Equipment Communication Wire(s) Included	

Certifications:



UL 60730-1



CSA E60730-1



Tier 3

 Title 24
JA13

4.2 SANCO₂ Water Heater

The SANCO₂ water heater utilizes CO₂ refrigerant to generate up to 15 kBtu/hr of hot water. The water heater can operate at temperatures as low as -25°F, and has a maximum noise level of 37 dBA. It requires 208V/240V, 15A service, and can be ground or wall mounted.

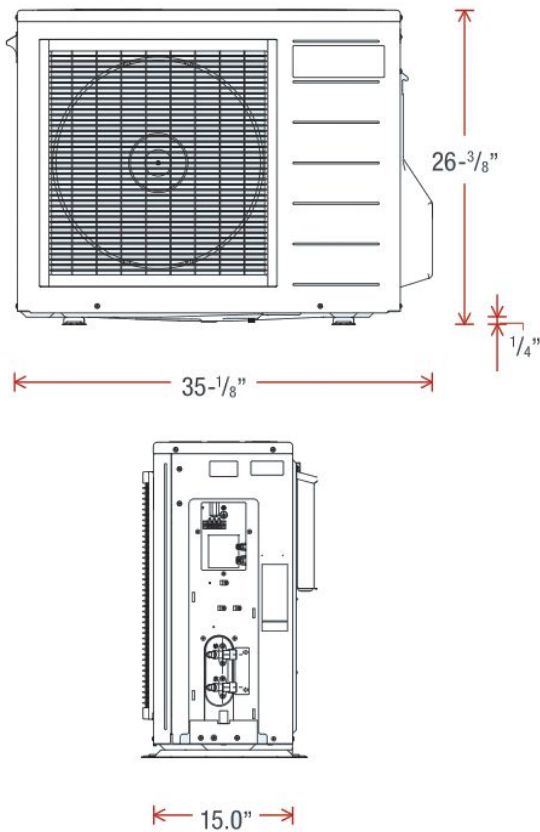

Certifications:



Model Number	GS4-45HPC	GS4-45HPC-D
Description	Standard	W/ drain pan heater for cold climates
Specifications		
Water Temperature Setting	145°F or 150°F	
Ambient Air Operating Range	-25°F to 104°F	-25°F to 114°F
Nominal Heating Capacity	15,400 Btu/hr	
Drain Pan Heating Power Consumption	N/A	132W
Heating COP @ 80/47/17 F	5.5 / 4.2 / 2.8	5.5 / 4.2 / 2.6
Refrigerant Type (Pre-Charged)	R744 (CO ₂)	
Voltage	240v-1Ph-60Hz	
Breaker Size	15A	
MCA	7.2A	
Compressor Type	Rotary	
Noise Level	37 DbA	
Approved for Potable Water	Yes	
Water Hardness	< 0.1 oz/gallon	
Water Chloride levels	< 0.1 oz/gallon	
Water pH	6.5 < pH < 8.5	
Dimensions		
Weight	108 lbs	
Connections (Supply/Return)	1/2"	
Max Length Including Vertical Steps	66 ft	
Max Vertical Separation	23 ft	
Max Incoming Water Pressure	95 PSI	75 PSI

4.3 Thermal Energy Storage

Harvest’s thermal energy storage utilizes a SANCO₂ tank. The tank is available in 119 gallons and 83 gallons, depending on the application. Both tanks consist of 4 inlet/outlet plumbing connections with built-in diffusers that allow the water to remain thermally stratified.

Both tanks also include a pressure relief valve port and built-in temperature sensor port.

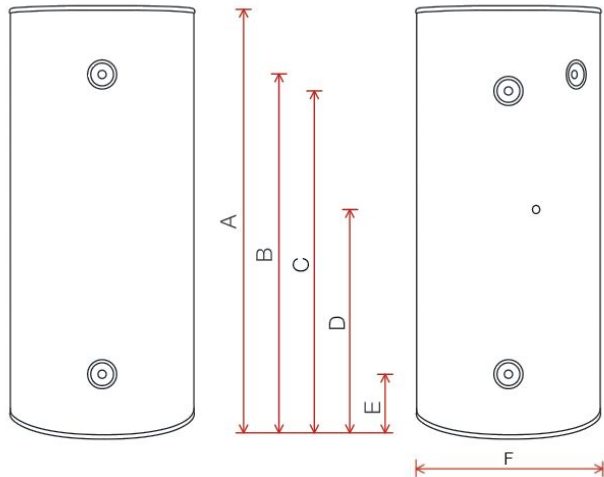



Model Number	SAN-83SSAQA	SAN-119GLBK
Capacity	83 gallons	119 gallons
Dimensions		
A: Height	68-7/8"	63-3/8"
B: Hot Water Outlet and PRV	60-1/4"	56"
C: Heat Pump Return	60-1/4"	60-1/4"
D: Sensor Port	40-5/8"	56"
E: Hydronic Return & Cold Water to HP	8-3/4"	4"
F: Diameter	24-1/2"	28"
Weight	115 lbs	345 lbs
Connections		
Hydronic Return	3/4" NPT	1-1/2" NPT
Hot Water Outlet	3/4" NPT	1-1/2" NPT
Hot Water Return from HP	3/4" NPT	3/4" NPT
Cold Water Inlet/Return to HP	3/4" NPT	3/4" NPT
Misc		
Material*	Stainless Steel	Glass-lined steel tank
Pressure Relief Setting	125 Psig / 210°F	125 Psig / 210°F
Warranty	15 years	10 years
<p>*Both tanks must be insulated to R-8 minimum conductive insulation value. Harvest carries a 3-inch lined fiberglass insulation blanket with R-10 value.</p>		

4.1 Field Supplied Plumbing Schedule for Potable side of Heat Exchanger

Symbol	Description	Qty	119 G Tank	83 G Tank	Notes
	1/2" and/or 3/4" general plumbing	TBD	X	X	Configuration is location dependent
	plumbing insulation	TBD	X	X	1" closed cell insulation on all plumbing runs, including the cold lines
A	1/2" isolation valves	5	X	X	
B	3/4" isolation valves	4	X	X	
ET	Expansion tank	1	X		Total volume >5 gal Acceptance Volume > 1.5 gal
		1		X	Total volume >3.5 gal Acceptance Volume > 1 gal
HB	1/2" hose bib drains	2	X	X	For purging and hydronic coil descaling
R&D	Reducers and dielectric connections for tank	2	X		Hex bushing reducer - 1 1/2" x 3/4" MPT x FPT, galvanized
		2	X		3/4" dielectric union or 6" of red brass (if using Copper plumbing) *
		2	X		Hex bushing reducer - 3/4" x 1/2" MPT x FPT, galvanized
		2	X		1/2" dielectric union or 6" of red brass (if using Copper plumbing) *
		2		X	Hex bushing reducer - 3/4" x 1/2" MPT x FPT, brass
		2		X	Hex bushing coupler - 3/4" MPT x FPT, brass
PRV	Pressure Regulating Valve	1	X	X	REQUIRED IF NOT ALREADY PRESENT. Must comply with AS1357.

* CA Plumbing Code, Section 315.3: All connections between ferrous and nonferrous pipe shall be made with a six-inch red brass nipple or a dielectric union.

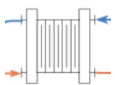
4.1 Field Supplied Plumbing Schedule for Radiant side of Heat Exchanger

Symbol	Description	Qty	119 G Tank	83 G Tank	Notes
	1/2" and/or 3/4" general plumbing	TBD	X	X	Configuration is location dependent
	plumbing insulation	TBD	X	X	1" closed cell insulation on all plumbing runs, including the cold lines
FM	Flow Meter (F8)	1	X	X	Part of Harvest Radiant Kit
TT	Temperature Sensor (T8)	1	X	X	Part of Harvest Radiant Kit
	Heat Exchanger	1	X	X	Brazed plate: approx. 4 sq. ft. internal surface area, 30 plates e.g., Bell & Gossett brazed plate, model BP400-030
	Radiant Circulator	1	X	X	Constant pressure circulator pump e.g., Grundfos Alpha2 15-55 or equivalent
	Throttling valves for each zone (with optional gauge)	TBD	X	X	Must be capable of being throttled down to operate in the [0.4 -1.2] gpm range

5. Low Voltage Wiring

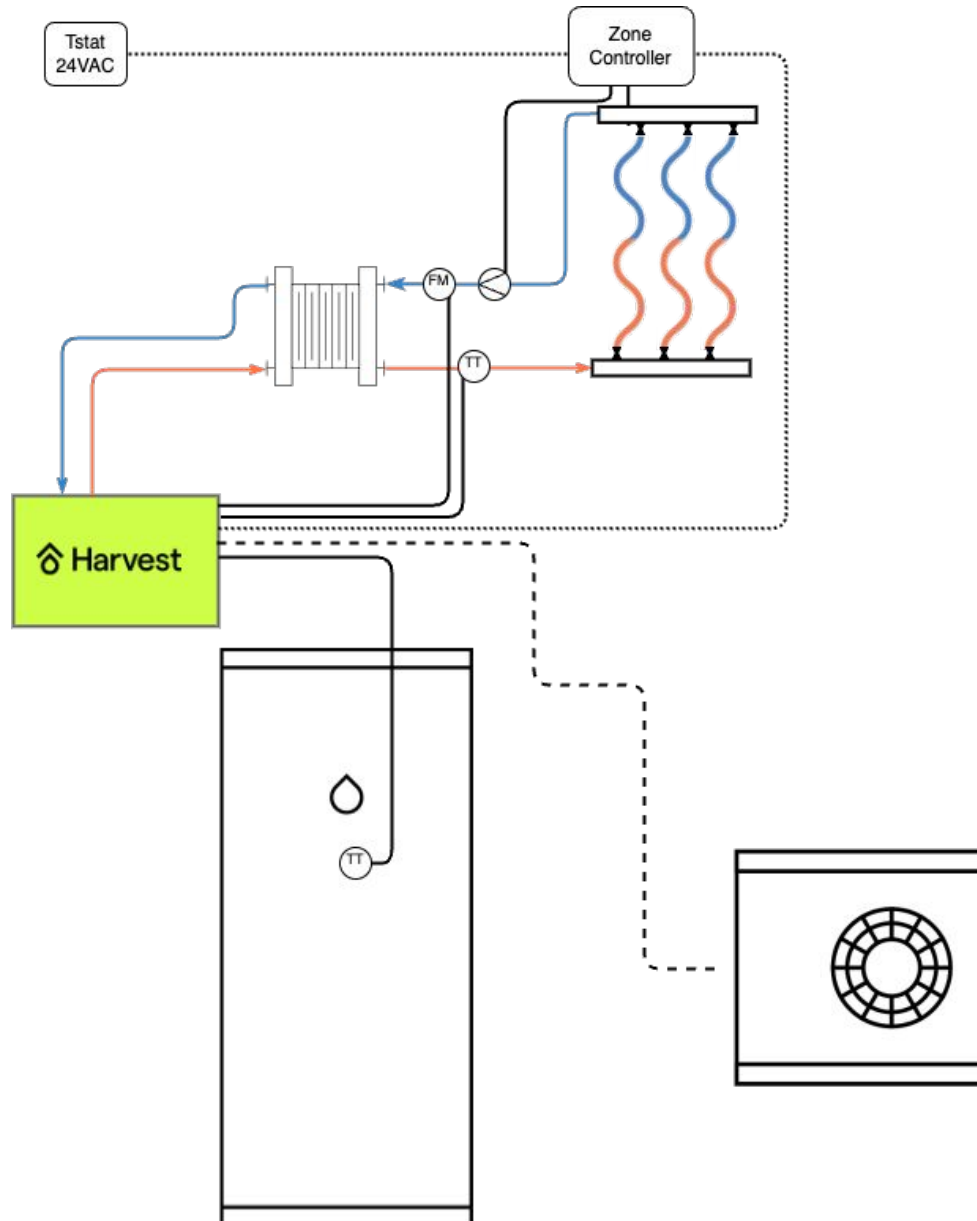

Icon	Description	Qty	Notes
.....	Thermostat wire	TBD	18-2
- - -	Cat5 communications cable	50'	Supplied with Harvest Pod
—	Tank thermistor cable	20'	Supplied with SANCO ₂ Tank
—	FM and TT wiring	TBD	Supplied with Harvest Radiant Kit
—	Circulator pump wiring (120V)	TBD	Supplied with Circulator

6. Commissioning

Commissioning the system consists of:

1. Connecting the system to WiFi if applicable
2. Setting the software parameters to match the hardware configuration
3. Verifying that wiring connections between the thermostat, zone controller, Harvest pod, SANCO₂ heat pump, and the SANCO₂ tank, are working properly
4. Configuring each independent radiant zone flow rate to maintain a low return temperature to the SANCO₂ heat pump while simultaneously maximizing the heat output.
5. Selecting the appropriate time-of-use rate where applicable.

Commissioning is supported by the *Harvest Tech* app which works on phones, tablets and laptops. See the Installation Manual for more information on how to use the app.

7. Support

Online documentation at docs.harvest-thermal.com:

- Owner documents
- Installation manuals
- Technical documents
- Quick Guides and Videos

24/7 remote monitoring and diagnostics are provided by Harvest as long as the Harvest Pod is internet connected.

Harvest Support: support@harvest-thermal.com, 510-962-6898, 9 AM-5 PM
Monday-Friday

8. Service

See the Harvest Service Manual under docs.harvest-thermal.com / Technical Documents.