

# Technical Specification Document

Harvest Open

# Technical Specifications

1.	System Overview	3
2.	System Components	4
3.	Operation & Performance	9
3.1	Sizing	9
3.2	Domestic Hot Water Performance	9
3.3	Thermal Battery Dispatchable Energy	9
3.4	Thermal Battery Usage Examples	10
4.	Plumbing	11
4.1	Field Supplied Plumbing Schedule	12
5.	Low Voltage Wiring	13
6.	Commissioning	14
7.	Support	14
8.	Service	14



Harvest Open integrates a Harvest Pod, the SANCO<sub>2</sub> heat pump water heater, and a third-party conventional refrigerant heat pump into a smart thermal battery heating and cooling system.

Harvest Open will shift heat pump operation from times of high costs and emissions to times of low costs and emissions, while always delivering heating and hot water when it is needed.

Harvest offers up to 30% reductions in heating and hot water energy costs and 90% in CO<sub>2</sub> emissions compared to gas. It protects your home from rising electric rates and provides resilient dispatchable heating energy when you need it.

Harvest Open is compatible with third-party conventional refrigerant heat pumps that use air handlers with 24 VAC controls. In addition, Harvest Open works well with solar photovoltaic and electrochemical battery systems (although neither is required for Harvest to work).

# 1. System Overview

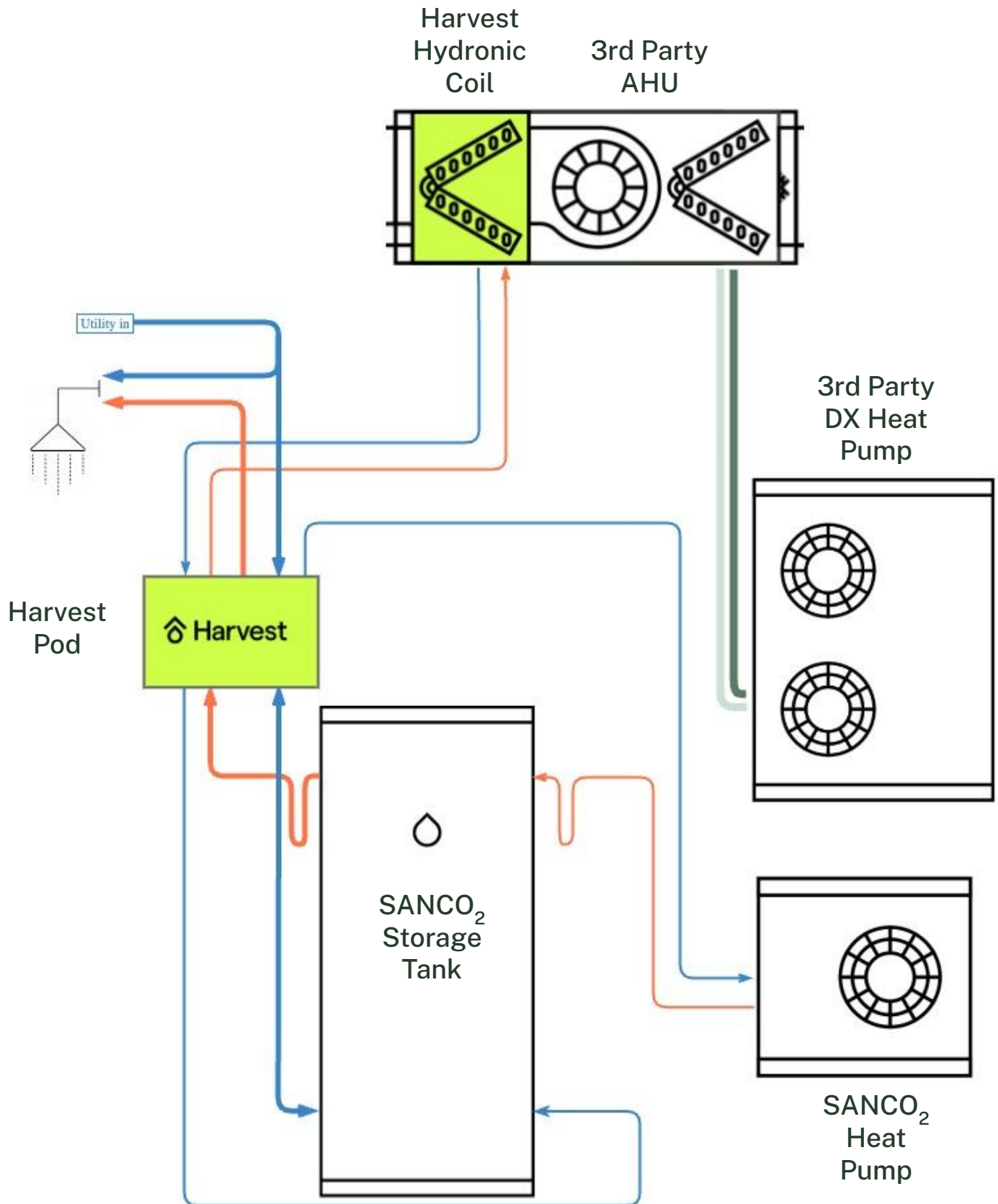

## 2. System Components

### 2.1 Harvest Pod

The Harvest Pod controls the state of charge of the thermal energy storage, predicts heating and hot water needs based on occupants usage patterns and weather forecast, optimizes when the heat pumps operate so they are most efficient and cost effective, and prioritizes DHW over home heating as needed. It also enables remote monitoring to identify issues such as DHW leaks, HPWH failure to start, circulator failure, and 3rd party HP failure.

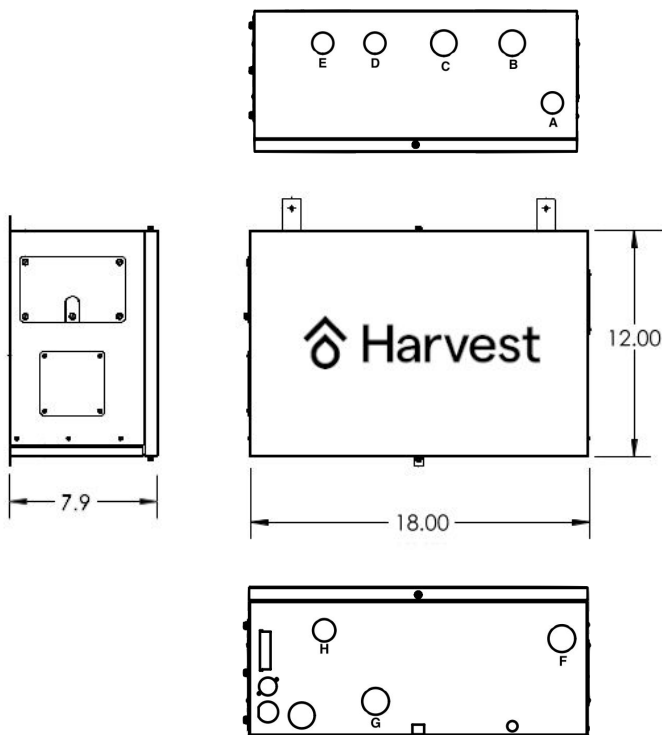

Configuration	Open
<b>Specifications</b>	
Operating Temperature	32°F to 122°F
Operating Humidity	5% to 95% rh
Max Hydronic Flow	1.6 gal/min
Power Supplies	24 VDC, 90W*; 24VAC**
Power Consumption: circulator off/on	2W/10 W
Wiring Connections	Screwless push-in terminal blocks & RJ45
Wiring	18 awg solid core & cat-5***
Networking	LAN/cat-5 (preferred) or wifi
<b>Plumbing Connections</b>	
Cold Water - Heat Pump (A)	1/2" NPT Male
Cold Water - Tank (F)	1/2" NPT Male
Hot Water - Tank (G)	3/4" NPT Male
DHW Hot (C)	3/4" NPT Male
Utility In (B)	3/4" NTP Male
Supply - To Coil / Heat Exchanger (D)	1/2" NPT Male
Return - To Coil / Heat Exchanger (E)	1/2" NPT Male
Return - Tank (H)	1/2" NPT Male
<b>Dimensions</b>	
Weight	33 lbs
Max Pipe Length to Coil	65 ft
Max Lift to Coil	35 ft
Max Incoming Water Pressure	75 psig
* Appropriate 24VDC Power Supply Included ** 24VAC Typically Supplied by R/C Connections on Air Handler *** Cat-5 Equipment Communication Wire(s) Included	

### Certifications:



UL 60730-1



CSA E60730-1



Tier 3

 Title 24  
JA13

## 2.2 SANCO<sub>2</sub> Water Heater

The SANCO<sub>2</sub> water heater utilizes CO<sub>2</sub> refrigerant to generate up to 15 kBtu/hr of hot water. The water heater can operate at temperatures as low as -25°F, and has a maximum noise level of 37 dBA. It requires 208V/240V, 15A service, and can be ground or wall mounted.

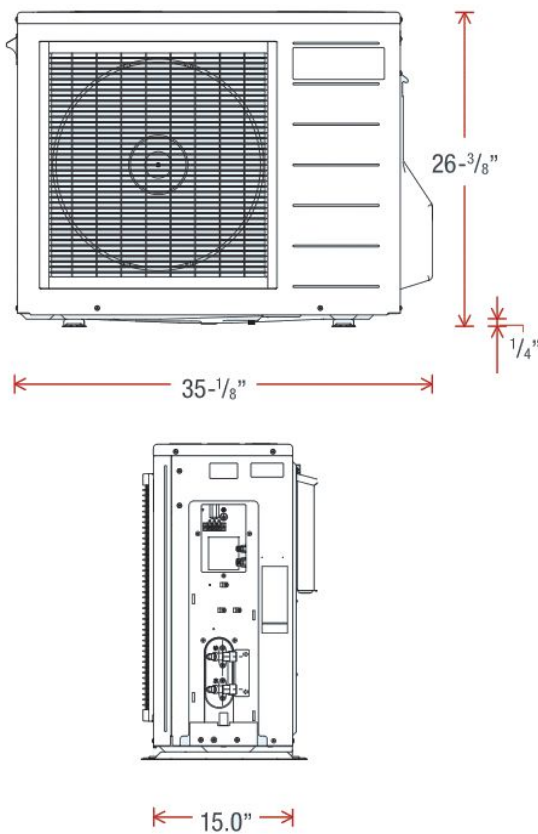

### Certifications:



Model Number	GS4-45HPC	GS4-45HPC-D
Description	Standard	W/ drain pan heater for cold climates
<b>Specifications</b>		
Water Temperature Setting	145°F or 150°F	
Ambient Air Operating Range	-25°F to 104°F	-25°F to 114°F
Nominal Heating Capacity	15,400 Btu/hr	
Drain Pan Heating Power Consumption	N/A	132W
Heating COP @ 80/47/17 F	5.5 / 4.2 / 2.8	5.5 / 4.2 / 2.6
Refrigerant Type (Pre-Charged)	R744 (CO <sub>2</sub> )	
Voltage	240v-1Ph-60Hz	
Breaker Size	15A	
MCA	7.2A	
Compressor Type	Rotary	
Noise Level	37 DbA	
Approved for Potable Water	Yes	
Water Hardness	< 0.1 oz/gallon	
Water Chloride levels	< 0.1 oz/gallon	
Water pH	6.5 < pH < 8.5	
<b>Dimensions</b>		
Weight	108 lbs	
Connections (Supply/Return)	1/2"	
Max Length Including Vertical Steps	66 ft	
Max Vertical Separation	23 ft	
Max Incoming Water Pressure	95 PSI	75 PSI

## 2.3 Thermal Energy Storage

Harvest’s thermal energy storage utilizes a SANCO<sub>2</sub> tank. The tank is available in 119 gallons and 83 gallons, depending on the application. Both tanks consist of 4 inlet/outlet plumbing connections with built-in diffusers that allow the water to remain thermally stratified.

Both tanks also include a pressure relief valve port and built-in temperature sensor port.

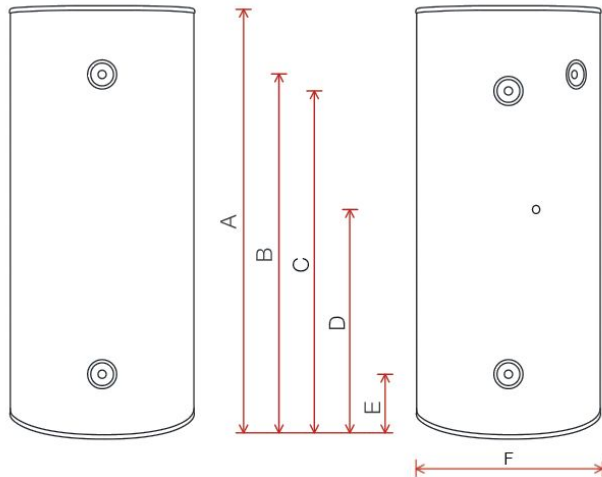

Model Number	SAN-83SSAQA	SAN-119GLBK
Capacity	83 gallons	119 gallons
Dimensions		
A: Height	68-7/8"	63-3/8"
B: Hot Water Outlet and PRV	60-1/4"	56"
C: Heat Pump Return	60-1/4"	60-1/4"
D: Sensor Port	40-5/8"	56"
E: Hydronic Return & Cold Water to HP	8-3/4"	4"
F: Diameter	24-1/2"	28"
Weight	115 lbs	345 lbs
Connections		
Hydronic Return	3/4" NPT	1-1/2" NPT
Hot Water Outlet	3/4" NPT	1-1/2" NPT
Hot Water Return from HP	3/4" NPT	3/4" NPT
Cold Water Inlet/Return to HP	3/4" NPT	3/4" NPT
Misc		
Material*	Stainless Steel	Glass-lined steel tank
Pressure Relief Setting	125 Psig / 210°F	125 Psig / 210°F
Warranty	15 years	10 years
*Both tanks <b>must be insulated to R-8</b> minimum conductive insulation value. Harvest carries a 3-inch lined fiberglass insulation blanket with R-10 value.		

## 2.4 Hydronic Coils

Hydronic coils come in two pre-enclosed configurations: a slab style coil and a higher-capacity A-Frame style. Both configurations are rated for potable water and are capable of being used in a “left-hand” or “right-hand” air flow direction. The coils can be mounted before or after the blower and other system blowers, but must be downstream of the air filter.

### HT-CB-MA-4

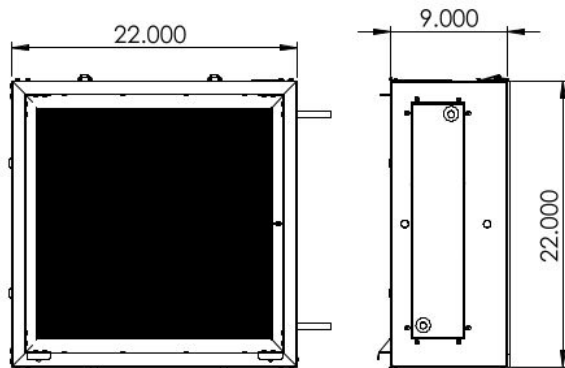

Model Number	HT-CB-MA-4-1	AH2-AF-HC-MA-0-1
Type	Slab	A-Frame
<b>Specifications</b>		
Nominal Capacity	30 kBtu/hr	46 kBtu/hr
Required Air Flow @ Max Nominal Capacity	1050 cfm	1600 cfm
Static Pressure Drop @ Max Nominal Capacity	0.34 in w.c.	0.34 in w.c.
Directional	No	
Approved for Potable Water	Yes	
Water Hardness	< 0.1 oz/gallon	
Water Chloride levels	< 0.1 oz/gallon	
Water pH	6.5 < pH < 8.5	
Design Temperature Rise	22°-28°F delta-T air temperature rise across the heating coil (400-500 CFM/ton heating).	
Weight	29 lbs	63 lbs
Coil Connections	2 x 3/8"	4 x 3/8"
Static Pressure Port Connections	2 x 1/8" Barb	2 x 1/8" Barb

**Hydronic Coil Air Pressure Drop**

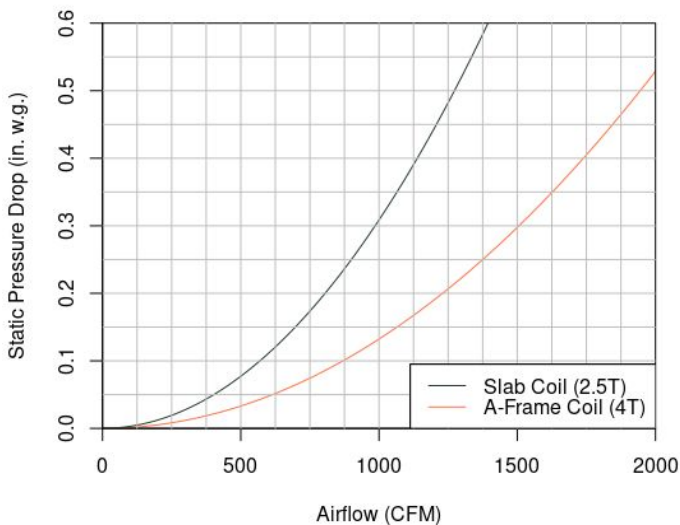

### AH2-AF-HC-MA-0-1

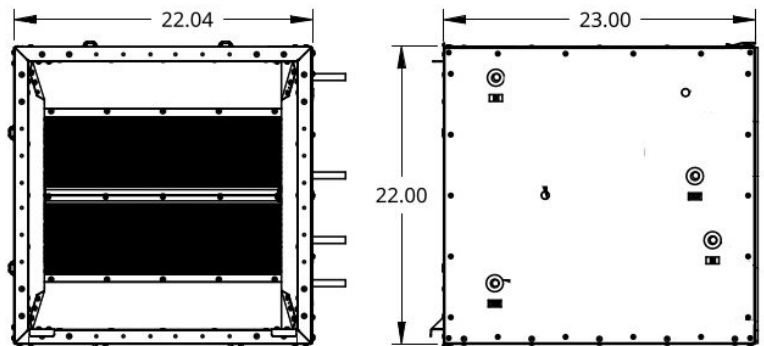

### 3. Operation & Performance

The Harvest Pod serves three primary purposes:

- manage the thermal battery system’s state of charge,
- monitor and predict heating and hot water demand based on the weather forecast and occupant usage patterns, and
- optimize the heat pump operating schedule to shift electricity usage from time of high price and emissions to times of low price and emissions, while always delivering heating and hot water whenever needed.

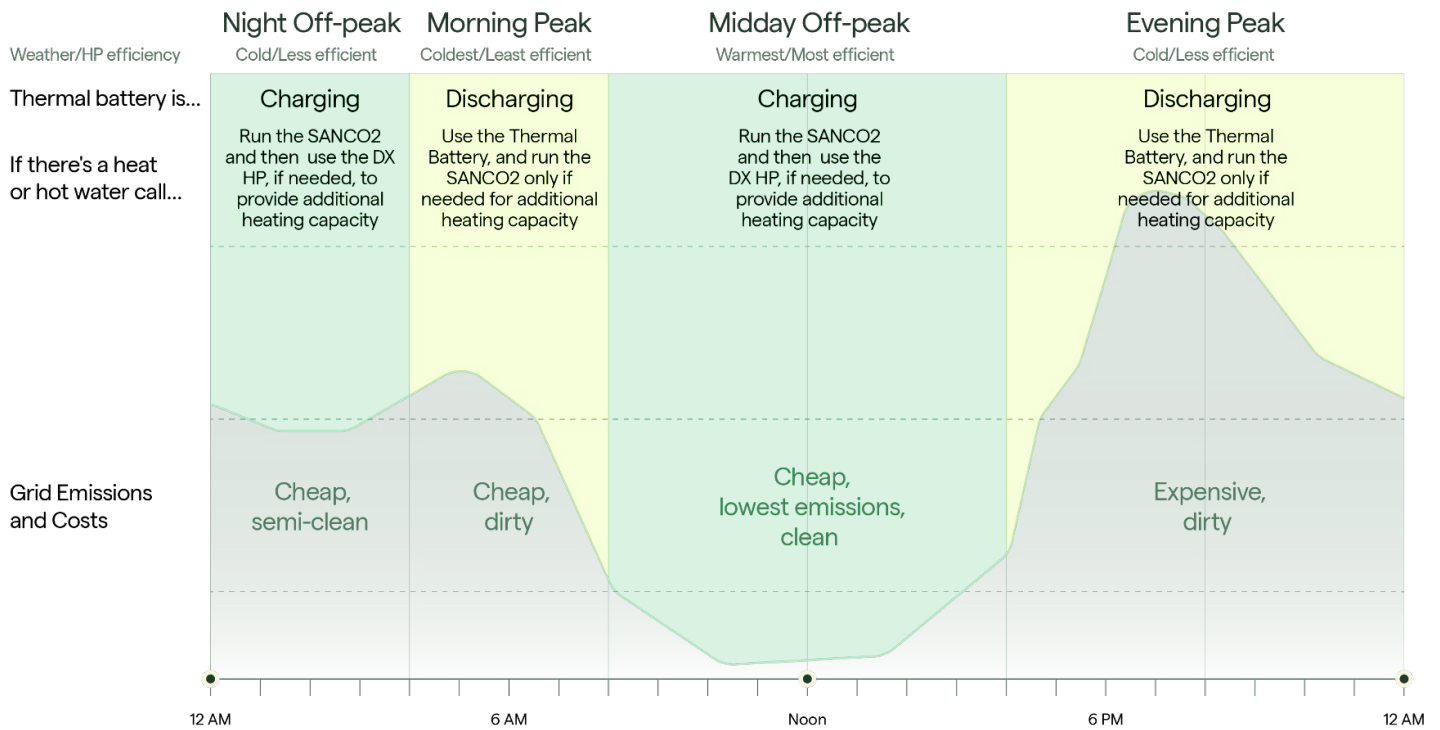

#### 3.1 Sizing

- i. Size the 3rd party DX heat pump for the home design heating load.
- ii. Choose the hydronic coil that enables the desired air flow for the design heating load (see Section 2.4, above).
- iii. Choose a thermal storage tank size based on the amount of dispatchable thermal energy desired (see Section 3.3 and 3.4, below)



### 3.2 Domestic Hot Water Performance

The SANCO<sub>2</sub> HP, controlled to run at the cheapest and cleanest times of day by the Harvest Pod, provides remarkable domestic hot water performance, capacity, and recovery as part of the Harvest Open application.

Domestic Hot Water Performance*			
Tank Capacity	83 G	119 G	166 G
Coefficient of Performance	up to 5.5	up to 5.5	up to 5.5
Nominal Heating Capacity	15.4 kBtu/hr	15.4 kBtu/hr	15.4 kBtu/hr

\* SANCO<sub>2</sub> performance data

### 3.3 Thermal Battery System Dispatchable Energy

Dispatchable energy is the quantity of energy from the thermal battery system that is used for heating and hot water during each discharge cycle. It represents how much energy can be shifted from peak times to off-peak times.

- In winter, the thermal battery system is typically cycled twice per day: once in the morning to serve heating and DHW needs, and once in the evening for heating and DHW needs. Dispatched energy is typically limited by thermal battery system capacity depending on the home energy needs.
- In summer, the thermal battery system is typically only charged once per day and only as much as needed to serve occupant needs until the next day. This may only be a third, or less, of the thermal battery system capacity depending on occupants' DHW needs, so dispatchable energy in summer is limited by energy demand rather than by thermal battery capacity.

Thermal Battery Dispatchable Energy Per Cycle			
	Storage Capacity		
	83 G	119 G	166 G
Heating Thermal Energy* (kBtu)	19	46	71
DHW Thermal Energy* ** (kBtu)	15	15	15
Combined DHW+Heating Thermal Energy* (kBtu)	34	61	86
Combined DHW+Heating Equivalent Electrical Load ***(kWh)	3.5	6.4	9.1

\* available for both a morning and an evening peak period

\*\* 30 gal of peak-coincident DHW usage

\*\*\*Assuming an average COP of 2.8

### 3.4 Thermal Battery Usage Examples

The Harvest Pod shifts the operation of both heat pumps from peak to off-peak as much as thermal storage capacity allows. In addition, the Harvest Pod prioritizes the most efficient, lowest-cost, highest-comfort hydronic heat whenever possible.

The following table provides an example of how the amount of dispatchable thermal energy, for a given tank size, will enable shifting the heating load for two “peak” times during a single day. The 3pm to midnight time range covers the evening Time of Use peak period for many electric utilities, and is often a time of high cost electricity. The 5am-9am time range generally has a high carbon footprint, is often the coldest time of day. The Time Of Use periods are configurable within the Harvest Tech App.

As an example, a 119 G tank in a home in San Jose with a 24 kBtu/hr design load would provide enough capacity to shift 99% of the annual heating load between the hours of 3 pm and midnight, and 90% of the 5am to 9am heating load.

Nominal Heating Load Shifting Examples								
			Nominal Heating Load shifted away from 5am to 9am			Nominal Heating Load Shifted away from 3pm to midnight		
CA climate zone	Design Temp.	Design Load kBtu/hr	83 G	119 G	166 G	83 G	119 G	166 G
CZ2 (Santa Rosa)	32F	12	91%	100%	100%	95%	100%	100%
		24	71%	95%	100%	82%	97%	100%
		36	59%	85%	96%	72%	92%	98%
		48	52%	76%	89%	66%	86%	94%
CZ3 (Oakland)	40F	12	88%	100%	100%	98%	100%	100%
		24	71%	93%	99%	94%	99%	100%
		36	60%	83%	93%	89%	97%	99%
		48	53%	76%	87%	84%	96%	98%
CZ4 (San Jose)	38F	12	84%	100%	100%	98%	100%	100%
		24	63%	90%	98%	91%	99%	100%
		36	53%	78%	91%	85%	96%	99%
		48	47%	69%	82%	80%	93%	97%
CZ12 (Sacramento)	34F	12	84%	100%	100%	97%	100%	100%
		24	63%	90%	98%	83%	99%	100%
		36	51%	77%	91%	73%	94%	99%
		48	44%	68%	82%	66%	88%	96%



## 4.1 Field Supplied Plumbing Schedule

Symbol	Description	Qty	119 G Tank	83 G Tank	Notes
	½" and/or ¾" general plumbing	TBD	X	X	Configuration is location dependent
	plumbing insulation	TBD	X	X	1" closed cell insulation on all plumbing runs, including the cold lines
A	½" isolation valves	5	X	X	
B	¾" isolation valves	4	X	X	
ET	Expansion tank	1	X		Total volume >5 gal Acceptance Volume > 1.5 gal
		1		X	Total volume >3.5 gal Acceptance Volume > 1 gal
HB	½" hose bib drains	2	X	X	For purging and hydronic coil descaling
R&D	Reducers and dielectric connections for tank	2	X		Hex bushing reducer - 1 ½" x ¾" MPT x FPT, galvanized
		2	X		¾" dielectric union or 6" of red brass (if using Copper plumbing) *
		2	X		Hex bushing reducer - ¾" x ½" MPT x FPT, galvanized
		2	X		½" dielectric union or 6" of red brass (if using Copper plumbing) *
		2		X	Hex bushing reducer - ¾" x ½" MPT x FPT, brass
		2		X	Hex bushing coupler - ¾" MPT x FPT, brass
	Plumbing reducer at hydronic coil	2 or 4	X	X	Fitting Reducer, FTG X C, 1/2" X 3/8" (2 for Slab coil, 4 for A-frame coil)
PRV	Pressure Regulating Valve	1	X	X	REQUIRED IF NOT ALREADY PRESENT. Must comply with AS1357.
LNS	Refrigerant lineset	1	X	X	Follow manufacturer's recommendations

\* CA Plumbing Code, Section 315.3: All connections between ferrous and nonferrous pipe shall be made with a six-inch red brass nipple or a dielectric union.

## 5. Low Voltage Wiring

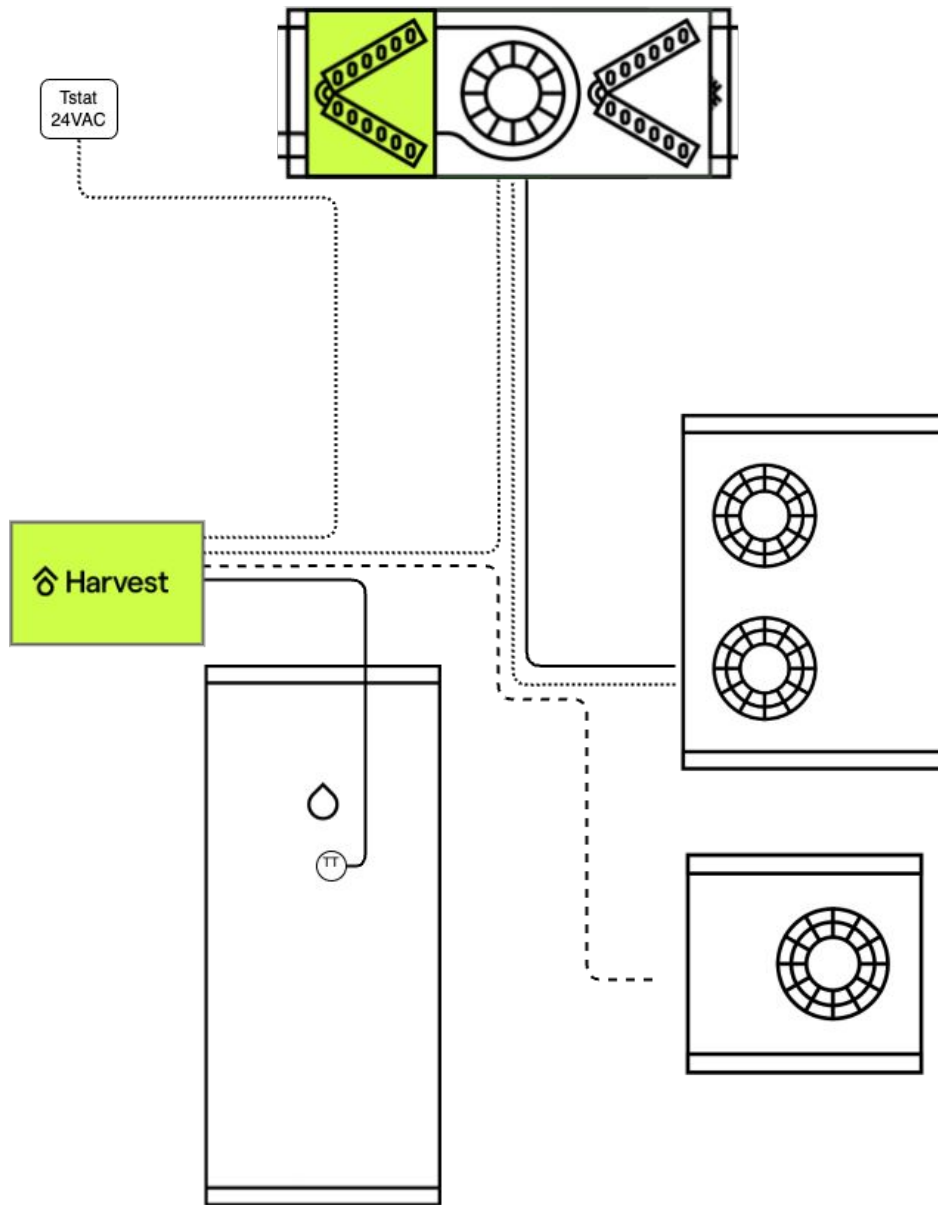

Icon	Description	Qty	Notes
.....	Thermostat wire	TBD	18-8, 18-6, and 18-2
- - -	Cat5 communications cable	50'	Supplied with Harvest Pod
—	Tank thermistor cable	20'	Supplied with SANCO <sub>2</sub> Tank
—	3rd-party heat pump communication wire	TBD	Follow manufacturer's recommendation

## 6. Commissioning

Commissioning the system consists of:

1. Connecting the system to WiFi if applicable
2. Setting the software parameters to match the hardware configuration
3. Verifying that wiring connections from the Harvest pod to the thermostat, SANCO<sub>2</sub> heat pump, SANCO<sub>2</sub> tank, and air handler are working properly
4. Configuring the hydronic heat output based on the home heating load
5. Configuring basic mode heat output
6. Selecting the appropriate time-of-use rate where applicable.

Commissioning is supported by the *Harvest Tech* app which works on phones, tablets and laptops. See the Installation Manual for more information on how to use the app.

## 7. Support

Online documentation at [docs.harvest-thermal.com](https://docs.harvest-thermal.com):

- Owner documents
- Installation manuals
- Technical documents
- Quick Guides and Videos

24/7 remote monitoring and diagnostics are provided by Harvest as long as the Harvest Pod is internet connected.

Harvest Support: [support@harvest-thermal.com](mailto:support@harvest-thermal.com), 510-962-6898, 9 AM-5 PM  
Monday-Friday

## 8. Service

See the Harvest Service Manual under [docs.harvest-thermal.com](https://docs.harvest-thermal.com) / Technical Documents.